

ERS4018X040 Eighth-Brick Power Converter



Features

- High efficiency, 89% (1.8V/40A)
- High output power
- Wide input voltage range: 36 – 75V
- Industry standard footprint and pin out
- Low profile, 0.37" (9.4mm)
- Robust stability
- Monotonic start-up
- No minimum load required
- Fixed frequency operation
- Basic insulation, 1500V
- UL[†]60950 certified
- RoHS Compliant Parts Available

Applications

- Telecom, Datacom, Networking
- Electronic Data Processing / Servers
- Distributed Power Architectures

Options

- Baseplate
- Auto-restart after fault shutdown
- Negative/Positive enable logic
- Various lead lengths

NetPower Technologies' ERS high current series 1/8-Brick DC-DC converters utilize proprietary technologies to achieve market leading efficiencies and thermal performance in the latest industry standard package. The ERS high current converters incorporate automated assembly techniques on a single board, planar magnetic, patented design which provides high performance and high reliability with a competitive cost. The low profile, open frame design provides industry leading conversion efficiency and thermal performance, making the ERS high current converters an excellent choice for today's densely packed systems.

NetPower's 1/8-brick ERS converters provide a monotonic start-up from both the input voltage and the ON/OFF control under all load conditions (including pre-biased output). These converters have a fast dynamic response and are stable over the full range of input voltage, load current, load capacitance, capacitor ESR, and temperature. The critical line and load regulations are tight, and the converters are fully protected from abnormal conditions of input/output voltages, output current and operating temperature. NetPower's converters are an ideal choice for any limited board space, high current and/or low output voltage applications such as telecom, datacom, wireless networks, or servers.

[†] UL is a registered trademark of Underwriters Laboratory Inc.

Absolute Maximum Rating

Excessive stresses over these absolute maximum ratings can cause permanent damage to the converter. Also, exposure to absolute maximum ratings for extended periods of time can adversely affect the reliability of the converter. Operation should be limited to the conditions outlined under the Electrical Specification Section.

Parameter	Symbol	Min	Max	Unit
Input Voltage (100 mS, operating)	V_i		100	Vdc
Input Voltage (continuous)	V_i	-0.5	80	Vdc
I/O Isolation Voltage (for 1 minute)		1500	-	Vdc
Operating Ambient Temperature (See Thermal Consideration section)	T_o	-40	85*	°C
Storage Temperature	T_{stg}	-55	125	°C

* For operation above 85°C ambient temperature, please consult NetPower for derating guidance.

Electrical Specifications

These specifications are valid over the converter's full range of input voltage, resistive load, and temperature unless noted otherwise.

Input Specifications

Parameter	Symbol	Min	Typical	Max	Unit
Input Voltage	V_i	36	48	75	Vdc
Standby Input Current	$I_{in, Stdby}$	-	8	12	mA
Inrush Transient	I^2t	-	-	1.0	A ² s
Input Turn-on Voltage Threshold	-	34	35	36	V
Input Turn-off Voltage Threshold	-	29	33	34	V
Input Voltage ON/OFF Hysteresis	-	1	3	4	V
Input Current	$I_{in, Max}$	-	-	3.2	A
Quiescent Input Current ($V_{in} = 48V$)	$I_{in, Qsnt}$	-	60	100	mA
Input Reflected-ripple Current, Peak-to-peak (5 Hz to 20 MHz, 12 μ H source impedance)	-	-	8	-	mA

General Specifications

Parameter	Symbol	Min	Typical	Max	Unit
Remote Enable					
Negative Logic:					
Logic Low – Module On	-	-	-	-	-
Logic High – Module Off					
Positive Logic:					
Logic High – Module On	-	-	-	-	-
Logic Low – Module Off					
Logic Low:					
$I_{ON/OFF} = 1.0mA$	$V_{ON/OFF}$	0	-	1.2	V
$V_{ON/OFF} = 0.0V$	$I_{ON/OFF}$	-	-	1.0	mA
Logic High:					
$I_{ON/OFF} = 0.0\mu A$	$V_{ON/OFF}$	-	-	15	V
Leakage Current	$I_{ON/OFF}$	-	-	50	μA
Turn-on Time ($I_o =$ full load, V_o within 1% of setpoint)		-	4	8	ms
Over-temperature Protection	T_o	-	120	-	°C
Isolation Capacitance	-	-	2700	-	pF
Isolation Resistance	-	10	-	-	M Ω
Calculated MTBF (Bellcore TR-332)			TBD		10 ⁶ -hour



ERS4018X040XXX (Vout = 1.8V, Iout = 40A)

Output Specifications

Parameter	Symbol	Min	Typical	Max	Unit
Output Voltage Set Point (Vi = 48 V; Io = Iomax; Ta = 25°C)	-	1.76	1.8	1.84	Vdc
Output Voltage Set Point (over all conditions)	-	1.75	-	1.85	Vdc
Output Regulation:					
Line Regulation (Vi = 36V to 75V, Io = 1/2 of load)	-	-	0.05	0.2	%Vo
Load Regulation (Io = Io,min to Io,max, Vi = 48V)	-	-	0.05	0.2	%Vo
Temperature (Ta = -40°C to 85 °C)	-	-	15	50	mV
Output Ripple and Noise Voltage RMS	-	-	-	40	mVrms
Peak-to-peak (5 Hz to 20 MHz bandwidth, Vin = 48V)	-	-	-	100	mVp-p
External Load Capacitance	-	-	-	30,000	µF
Output Current	Io	0	-	40	A
Output Power	Po	0	-	72	W
Output Current-limit Trip Point	Io,cli	41.2	47	52	A
Output Short-circuit Current			0		A
Efficiency (Vi = 48V; Io = Iomax, TA = 25°C)	η	-	89%	-	%
Output Over Voltage trip point		2	2.25	2.5	V
Switching frequency	-	280	300	320	kHz
Dynamic Response (Vi = 48V; Ta = 25°C; Load transient 0.1A/µs)					
Load step from 50% to 75% of full load:					
Peak deviation			4		%Vo
Settling time (to 10% band of Vo deviation)			200		µs
Load step from 50% to 25% of full load:					
Peak deviation			4		%Vo
Settling time (to 10% band of Vo deviation)			200		µs
Input Ripple Rejection			60		dB
Output Voltage Trim Range	-	80	-	110	%Vo
Output Voltage Remote-sense Range	-	-	-	0.18	V

Characteristic Curves

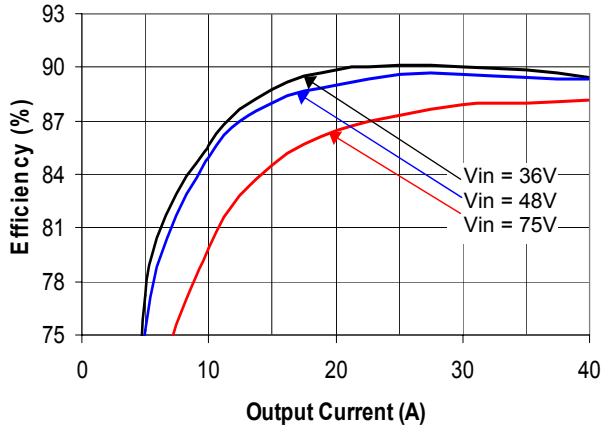

Fig. 1. Efficiency vs. Load Current (25°C)

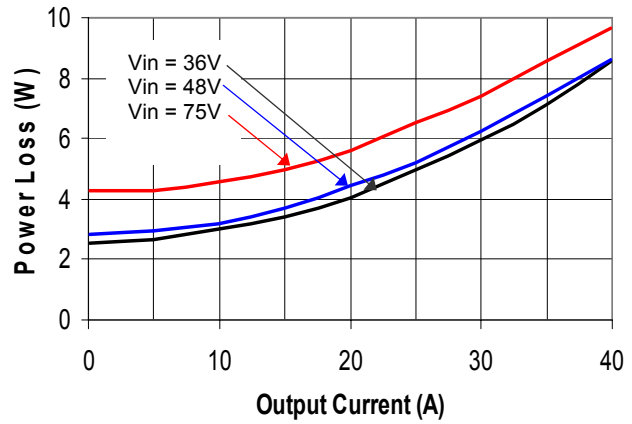

Fig. 2. Power Loss vs. Load Current (25°C)

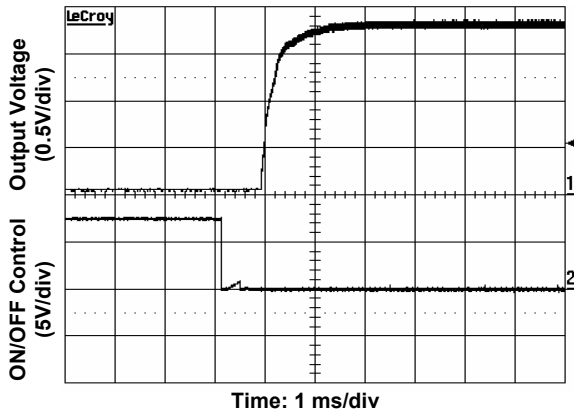

Fig. 3. Start-Up from Enable Control

Input voltage 48V, Output current 0A

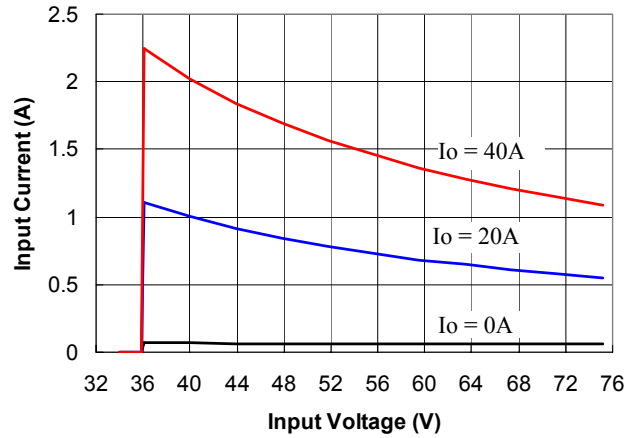

Fig. 4. Input Characteristic

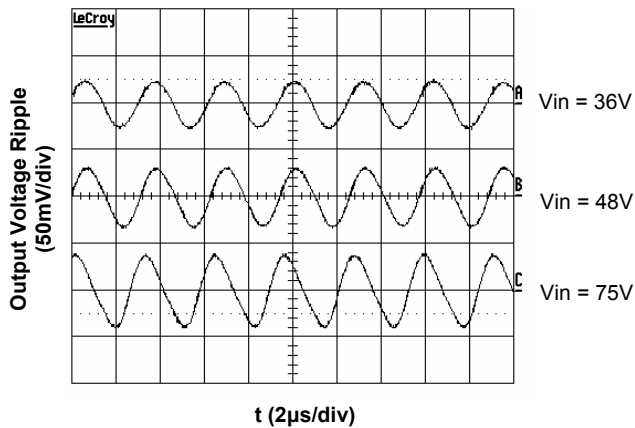

Fig. 5. Output Ripple Voltage at full Load

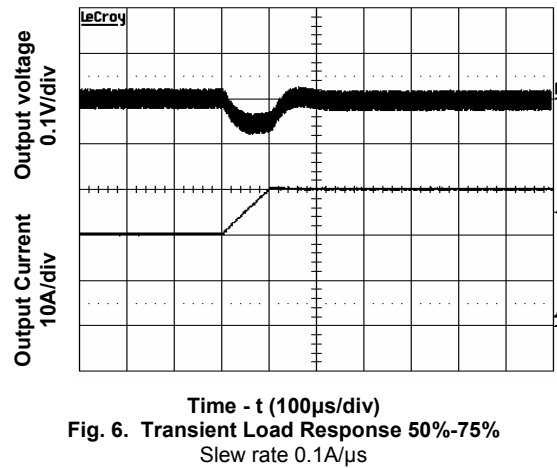
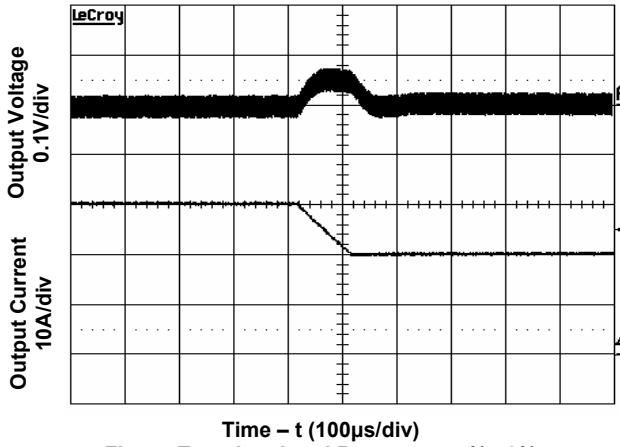
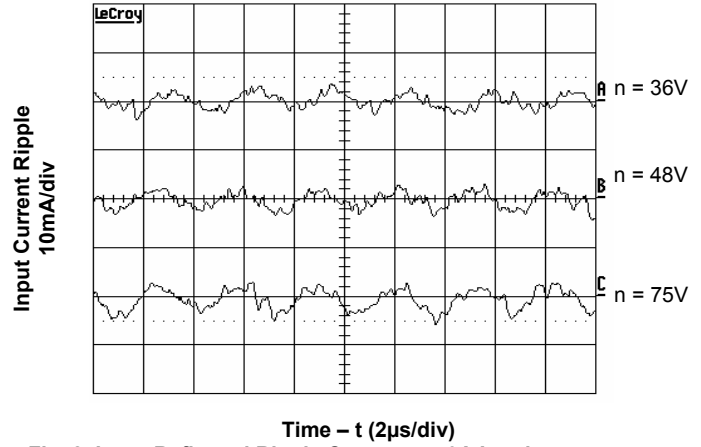

Fig. 6. Transient Load Response 50%-75%
Slew rate 0.1A/µs



Time – t (100µs/div)
Fig. 7. Transient Load Response 75%-50%
Slew rate 0.1A/µs



Time – t (2µs/div)
Fig. 8. Input Reflected Ripple Current at 40A Load

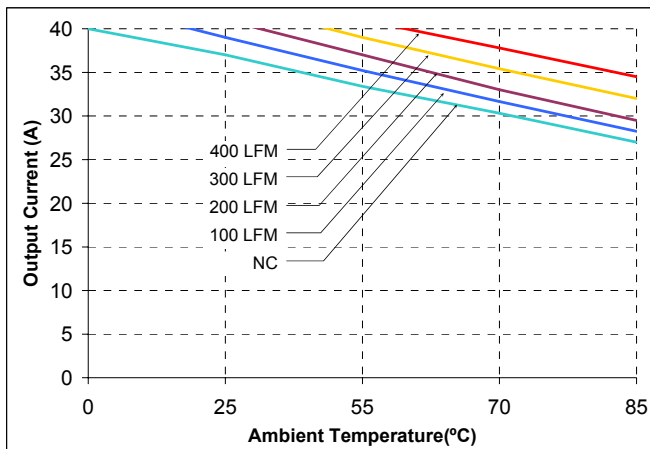

Fig. 9. Current Derating Curve for Airflow Direction 1.
(Ref. Fig. 10 for Airflow Direction; Vin = 48V open frame unit)

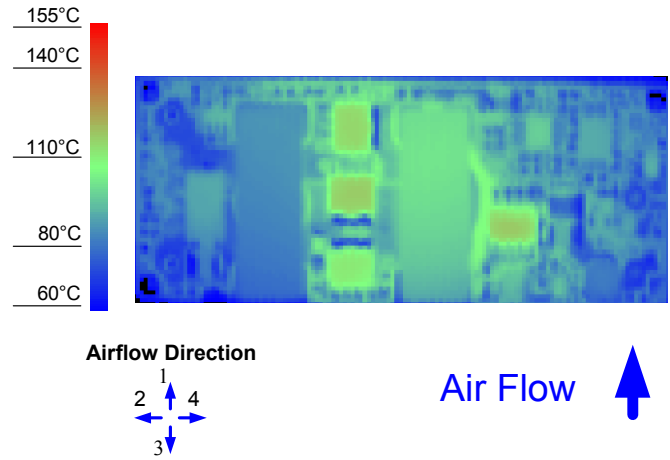

Fig. 10. Thermal Image for Airflow Direction 1 (40A output, 62°C ambient, 200 LFM, Vin = 48V open frame unit)

Feature Descriptions

Remote ON/OFF

The converter can be turned on and off by changing the voltage or resistance between the ON/OFF pin and Vin(-). The ERS Series of converters is available with factory selectable positive logic or negative enabling logic.

For the negative control logic, the converter is ON when the ON/OFF pin is at a logic low level, and OFF when the ON/OFF pin is at a logic high level. With positive control logic, the converter is ON when the ON/OFF pin is at a logic high level and OFF when the ON/OFF pin is at a logic low level.

With the internal pull-up circuitry, a simple external switch between the ON/OFF pin and Vin(-) can control the converter. A few example circuits for controlling the ON/OFF pin are shown in Figs. 11, 12 and 13.

The logic-low level is from 0V to 1.2V, and the maximum switch current during logic low is 1mA. The external switch must be capable of maintaining a logic-low level while sinking this current. The maximum ON/OFF pin voltage, generated by the converter internal circuitry for logic-high level, is less than 15V. The maximum allowable leakage current from this pin at logic-high level is 50µA.

Remote SENSE

The remote SENSE pins are used to sense voltage at the load point to accurately regulate the load voltage and eliminate the impact of the voltage drop in the power distribution path.

The SENSE(+) and SENSE(-) pins should be connected to the point where regulation is desired. The voltage difference between the SENSE pins and the output pins must not exceed remote-sense voltage range in the Output Specification Table:

$$[V_{out(+)} - V_{out(-)}] - [SENSE(+)- SENSE (-)] < \text{Min of 10\% nominal output voltage or 0.5V}$$

When remote sense is not used, the SENSE pins should be connected to their corresponding output terminals (positive and negative). If the SENSE pins are left floating, the converter will deliver an output

voltage slightly higher than its specified typical output voltage. The OVP (output over-voltage protection) circuit senses the voltage across the output pins (Pin 10 and Pin 6), so the total voltage rise should not exceed the minimum OVP setpoint given in the Specifications Table in operation.

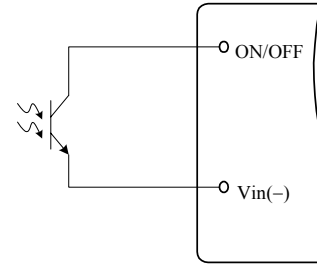

Fig. 11. Opto Coupler Enable Circuit

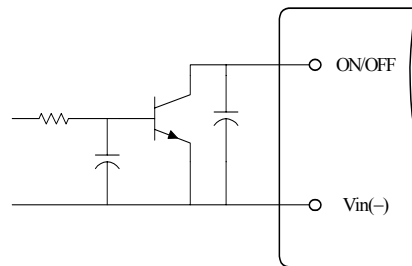

Fig. 12. Open Collector Enable Circuit

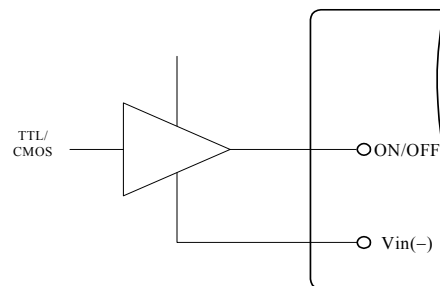

Fig. 13. Direct Logic Drive

Output Voltage Adjustment (Trim)

The trim pin allows the user to adjust the output voltage set point. To increase the output voltage, an external resistor should be connected between the TRIM pin and the SENSE(+) pin. To decrease the output voltage, an external resistor should be connected between the TRIM pin and the SENSE(-) pin. The output voltage trim range of ERS converters is 90% to 110% of the converter's specified nominal output voltage.

The output voltage can be adjusted down by changing the value of the external resistor using the equation below:

$$R_{down} = \left(\frac{511}{\Delta} - 10.22 \right) (k\Omega)$$

Where

$$\Delta = \left(\frac{|V_{nom} - V_{adj}|}{V_{nom}} \right) \times 100$$

and

V_{nom} = Nominal Voltage
 V_{adj} = Adjusted Voltage

The circuit configuration for trim down operation is shown in Fig. 14.

The output voltage can be adjusted up by changing the value of the external resistor using the equation below:

If $V_{out} \geq 1.8V$:

$$R_{up} = \left(\frac{5.11V_o(100 + \Delta)}{1.225\Delta} - \frac{511}{\Delta} - 10.22 \right) (k\Omega)$$

If $V_{out} < 1.8V$:

$$R_{up} = \left(\frac{5.11V_o(100 + \Delta)}{0.6\Delta} - \frac{511}{\Delta} - 10.22 \right) (k\Omega)$$

Where

V_o = Nominal Output Voltage

And
$$\Delta = \left(\frac{|V_{nom} - V_{adj}|}{V_{nom}} \right) \times 100$$

The circuit configuration for trim up operation is shown in Fig. 15.

When remote sense and trim functions are used simultaneously, please do not allow the output voltage at the converter output terminals to be outside the voltage trim range specified operating range when using the trim up and/or remote sense functions. It is important not to exceed the maximum power rating of the converter as shown in the Specifications Table.

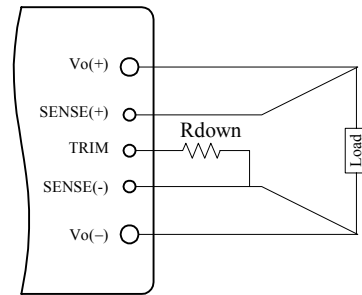

Fig. 14 Circuit to Decrease Output Voltage

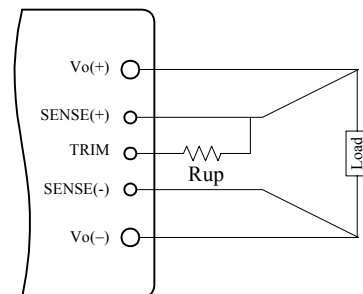

Fig. 15 Circuit to Increase Output Voltage

Input Under-Voltage Lockout

This feature prevents the converter from turning on until the input voltage reaches 35V (typical). It turns the converter off when the input voltage falls below 32V (typical). A 3V hysteresis prevents oscillations.

Output Over-Current Protection

As a standard feature, the converter latches off when the load current exceeds the current limit. The converter can be restarted by toggling the ON/OFF switch, or by recycling the input voltage. With the auto-restart option, the converter will operate in a hiccup mode (repeatedly trying to restart) until the over-current condition is cleared.

Output Over-Voltage Protection

If the voltage across the output pins exceeds the output voltage protection threshold as shown in the Specifications Table, the converter will shut down to protect the converter and the load.

As a standard feature, the converter will shut down and latch off when this occurs. The converter can be restarted by toggling the ON/OFF switch, or by recycling the input voltage. With the auto-restart option, the converter will operate in hiccup mode until the over-voltage cause is cleared.

Thermal Shutdown

As a standard feature, the converter will shut down and latch off if an over-temperature condition is detected. The converter has a temperature sensor located within the converter's circuit board, which detects the thermal condition of key components of the converter.

The thermal shutdown circuit is designed to turn the converter off when the temperature at the sensor reaches 120°C. The module can be restarted by toggling the ON/OFF switch, or by recycling the input voltage. With the auto-restart option, the converter will resume operation after the converter cools down.

Design Considerations

Input Source Impedance

The stability of the ERS converters, as with any DC/DC converter, may be compromised if the source impedance is too high or too inductive. It's desirable to keep the input source AC impedance as low as possible. The converters are designed to be stable without an additional input capacitor for typical source impedance. However, it is recommended to use at least a 33 μ F low ESR electrolytic capacitor at the input of the converter to reduce the potential impact of the source impedance. This electrolytic capacitor should have sufficient RMS current rating over the operating temperature range to avoid overheating.

Safety Considerations

The ERS Series of converters are designed in accordance with EN 60950 Safety of Information Technology Equipment Including Electrical Equipment. The converters are designed to meet 1500V Basic Insulation requirements in UL 60950, Safety of Information Technology Equipment and applicable Canadian Safety Requirement, and ULC 60950. Flammability ratings of the PWB and plastic components in the converter meet 94V-0.

For the ERS series converters to meet basic insulation requirements when a baseplate or heatsink are used, the case pin must be left floating, or connected to a primary or secondary circuit through a capacitor with the appropriate voltage rating. If no baseplate or heatsink are used, the case pin can be connected directly to any primary circuit.

To protect the converter and the system, an input line fuse is highly recommended on the input end that is not grounded.

A normal-blow fuse with a maximum rating of 25A should be connected at the ungrounded input lead of each ERS series converter.

Thermal Considerations

The ERS Series of converters can operate in various thermal environments. Due to the high efficiency and optimal heat distribution, these converters exhibit excellent thermal performance. Most heat-generating components are mounted on the topside of the

module, so the heat can be easily removed by conduction, convection, and radiation. Proper cooling can be verified by monitoring the temperature of the key components. Fig. 16 shows recommended temperature monitoring points. The temperature at these locations should not exceed 120 °C continuously.

The maximum allowable output power of any power converter is usually determined by the electrical design and the maximum operating temperature of its components. The ERS series of converters has been tested comprehensively under various conditions to generate the derating curves with consideration for long term reliability.

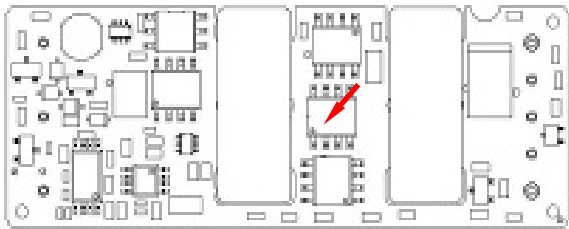

Fig. 16. Temperature Monitoring Locations

Thermal derating curves are highly influenced by derating guide, the test conditions and test setup, such as test temperatures, the interface method between the converter and the test fixture board, spacing and construction of the fixture board and the spacing board, temperature measurement method, and the ambient temperature measurement point. The derating curves in this data sheet are obtained by thermal tests in a wind tunnel. The converter's power pins are soldered to a 2-layer 1-ounce copper test fixture board through thermal relief. The space between the test board and a PWB spacing board is 1". Usually, the end system board has more layer count, and has better thermal conduction than our test fixture board. For thermal considerations specific to your application environment, please contact NetPower's technical support team for assistance.

Heat Transfer without a Baseplated/or Heatsink

Convection heat transfer is the primary cooling means for converters without a baseplate. Therefore, airflow speed is important for any intended operating

environment. Increasing the airflow over the converter enhances the heat transfer via convection.

Fig. 9 shows the current derating curves under nominal input voltage. To maintain long-term reliability, the module should be operated within these curves in steady state. Note: the natural convection condition can be measured from 0.05 - 0.15 m/s (10 - 30 LFM).

Heat Transfer with a Baseplate or Heatsink

Baseplates or heatplates, an optional feature, are metal plates to conduct heat out of the converters and provide attachment to external heatsinks or mechanical structures. The ERS series converters can use baseplates to further enhance their thermal performance. The maximum height of a ERS converter with a baseplate is 0.50". A baseplate works as a heat spreader, and thus can improve the heat transfer between the converter and its ambient.

An additional heatsink or cold-plate can be attached to the baseplate using M3 screws. The heatsink/cold plate further improve the thermal performance of the converter. For high volume applications, NetPower also offers an integrated heatsink option. The integrated-heatsink option combines the baseplate and heatsink into one assembly, with fins in the transverse direction. The maximum converter height with this option is not greater than 0.75". The integrated heatsink thermally outperforms the combination of a baseplate with a 0.5" heatsink.

An optional case pin is available with the baseplate and integrated heatsink options.

EMC Considerations

The ERS series of converters meet the EN55022 class B and FCC part 15J requirements with an external filter. The EMC performance of the ERS converters is related to the layout and filtering design of the system board. Careful layout and adequate filtering around the module are important to confine noise generated by the converter, and to optimize the system EMC performance.

For assistance with designing for EMC compliance, please contact NetPower's technical support team at support@netpowercorp.com.

Mechanical Information

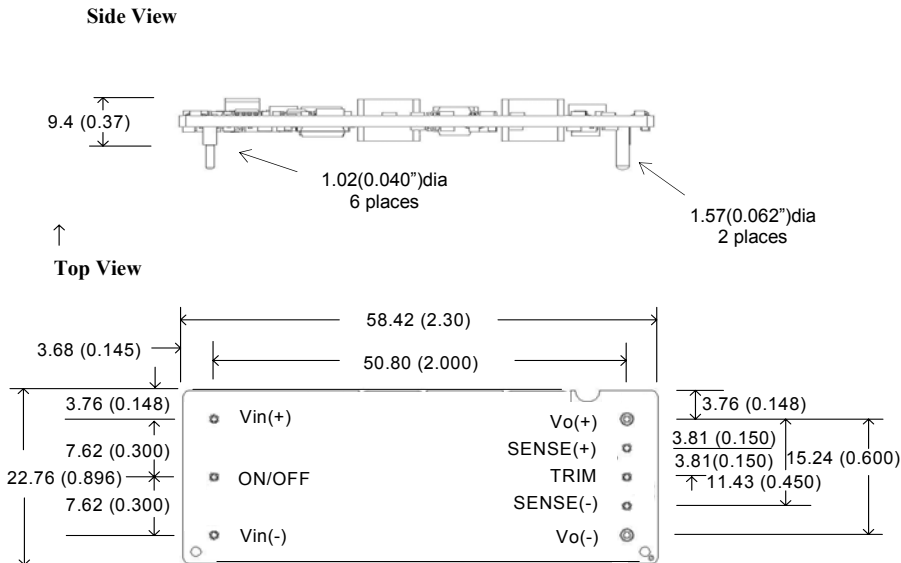

Fig. 17. Open Frame Converter

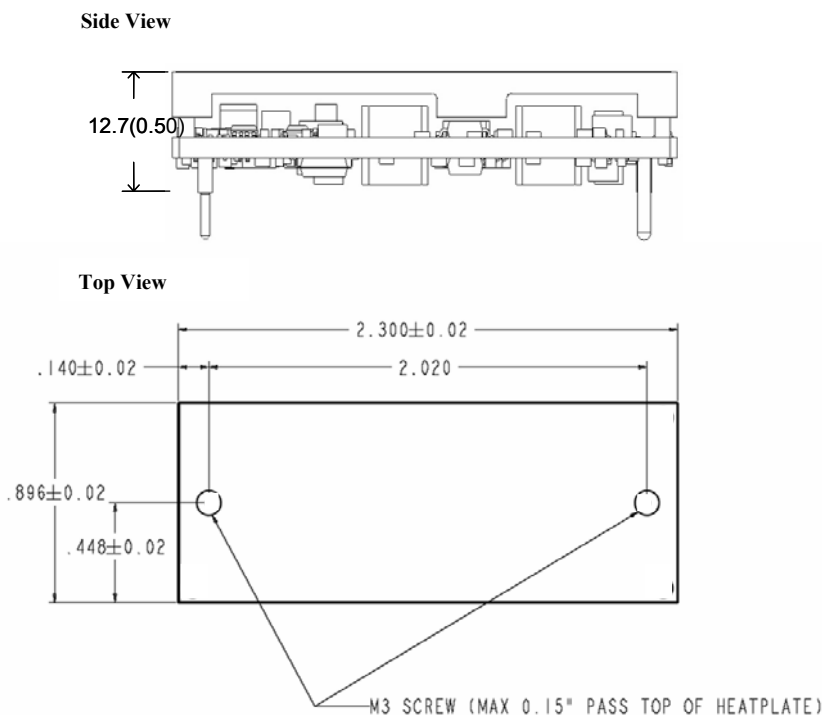

Fig. 18. Converter with optional baseplate

Notes

- 1) All dimensions in mm (inches)
Tolerances: .x ± .5 (.xx ± 0.02)
.xx ± .25 (.xxx ± 0.010)
- 2) Input and control pins are 1.02mm (0.040") dia. with 1.68mm (0.066") dia. standoff shoulders. Output pins are 1.57 mm (0.062") dia with 2.49mm (0.098") dia. standoff shoulders. All pins are coated with 90%/10% solder finish, or Matte Tin for Pb free products.
Weight: 25.5 g
Workmanship: Meet or exceeds IPC-A-610 Class II
Torque applied on screws should not exceed 6in-lb(0.7 Nm).
Baseplate flatness tolerance is 0.10mm (0.004") TIR for surface
If M3 screws are used to attach heatsink to the baseplate, the screw length from the top surface of baseplate going down should not exceed 3.8 mm (0.15 in) max .

Part Numbering System

Package	Series	Number of Outputs	Input Voltage	Output Voltage	ON/OFF Logic	Output Current	Pin Length	Feature Set "A"	Feature Set "B"
E	R	S	4	025	N	035	N	2	1
E-1/8 brick	R-regular	S-single	4: 36-75V	025-2.5V	P- positive N- negative	035-35A	K - 0.110" N - 0.145" R - 0.180"	0- no option 2- auto-restart	0- no option 1- baseplate 5- Pb free 6- Pb free with baseplate

Note: In Feature Set B, option 0-5 indicates parts with RoHS-5 compliance (having Lead in solder), and option 6-9 indicates completely RoHS compliance (including Lead free).

Part Numbering Example: **ERS4025N035N21**

Denotes a 1/8 brick module with 48 Vin single output (i.e., 36-75V), 2.5Vout, negative remote control logic, 35Aout, 0.145" pin length, auto-restart feature, and a baseplate.

For more information, please contact:

 **NetPower** Technologies, Inc.
Toll Free: 866-NETPOWER (638-7693)
Local Phone: 972-560-0500
Fax: 972-560-0210
E-mail: sales@netpowercorp.com
Address: 1680 Prospect Dr., Suite 200
Richardson, TX 75081

Warranty

NetPower offers a three (2) year limited warranty. Complete warranty information is listed on our web site or is available upon request. Information furnished by NetPower is believed to be accurate and reliable. However, no responsibility is assumed by NetPower for its use, nor for any infringements of patents or other rights of third parties which may result from its use. No license is granted by implication or otherwise under any patent or patent rights of NetPower.